

# 29F0818-1SR-10

**UNCONTROLLED DOCUMENT**

PHYSICAL DIMENSIONS:

A	11.43 [.450]	+ 0.18 [.007]
B	4.50 [.177]	+ 0.08 [.003] - 0.10 [.004]
B1	7.04 [.277]	+ MAX
C	4.19 [.165]	+ 0.10 [.004]
C1	4.83 [.190]	+ MAX
D	2.24 [.088]	+ 0.08 [.003]
E	1.27 [.050]	+ 0.13 [.005]

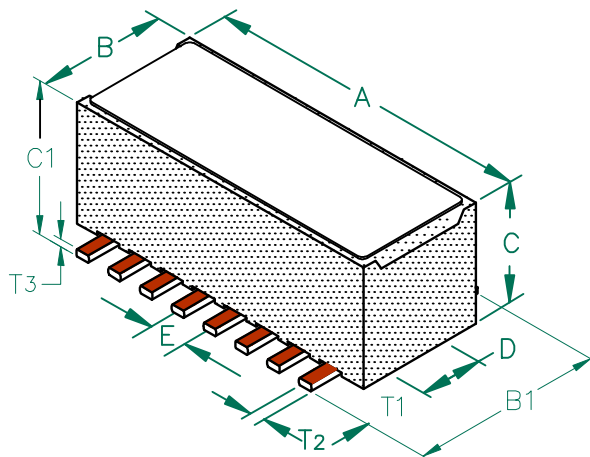

PHYSICAL DIMENSIONS:

T1	2.16 [.085]	+ 0.25 [.010]
T2	0.50 [.020]	+ TYP.
T3	0.25 [.010]	+ TYP.

ELECTRICAL CHARACTERISTICS:			
Z @ 100MHz ( $\Omega$ )	DCR ( $\Omega$ )	Rated Current	
Nominal	119		
Minimum	90		
Maximum	149	0.01	6,000 mA

NOTES: UNLESS OTHERWISE SPECIFIED

1. TAPED AND REELED per CURRENT EIA SPECIFICATIONS 13" REELS, 900 PCS/REEL.
2. COMPONENTS SHOULD BE ADEQUATELY PREHEATED BEFORE SOLDERING.
3. REF. CARRIER TAPE SPECIFICATION # CART 818-13.
4. TERMINATION FINISH IS 100% TIN.



|Z|, R, AND X vs. FREQUENCY

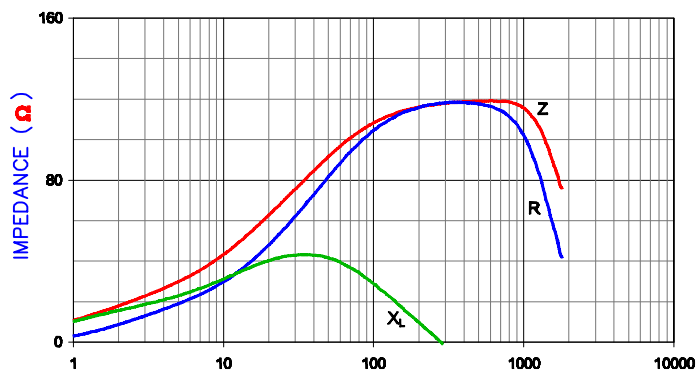

**Z**      **R**      **X<sub>L</sub>**

LAND PATTERNS FOR REFLOW SOLDERING

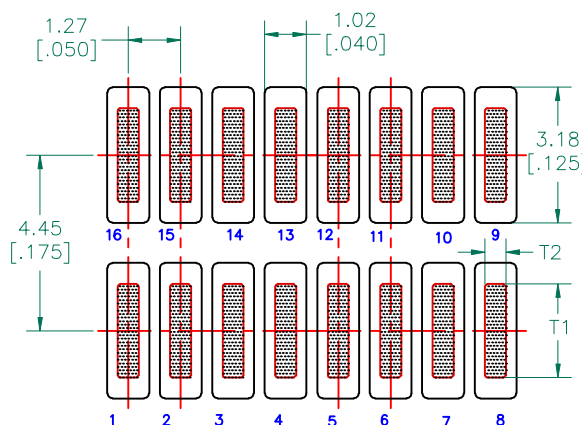

RECOMMENDED SOLDERING CONDITIONS

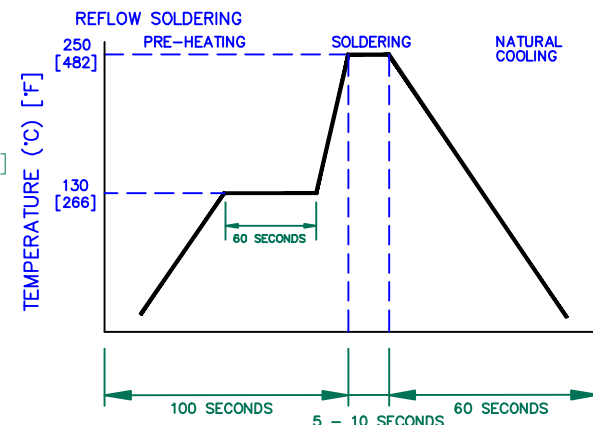

DIMENSIONS ARE IN mm [INCHES]				This print is the property of Laird Tech. and is loaned in confidence subject to return upon request and with the understanding that no copies shall be made without the written consent of Laird Tech. All rights to design or invention are reserved.	
E	UPDATE COMPANY LOGO	10/22/08	JRK	PROJECT/PART NUMBER: <b>29F0818-1SR-10</b>	REV <b>E</b>
D	UPDATE COMPANY LOGO	05/04/07	JRK		
C	CHG TOLS ON E DIMS CORRECT T2 DIMS IN LANDPATTERN	03/21/07	JRK	DATE: 04/30/04	SCALE: NTS
B	COR REV BLOCK mm [INCHES] ADD ROHS	10/19/06	JRK		
A	ORIGINAL DRAFT	04/30/04	JRK	CAD # 29F0818-1SR-10-E-2	TOOL # H0818
REV	DESCRIPTION	DATE	INT		

